

SIMME-SEAT INSTALLATION INSTRUCTIONS

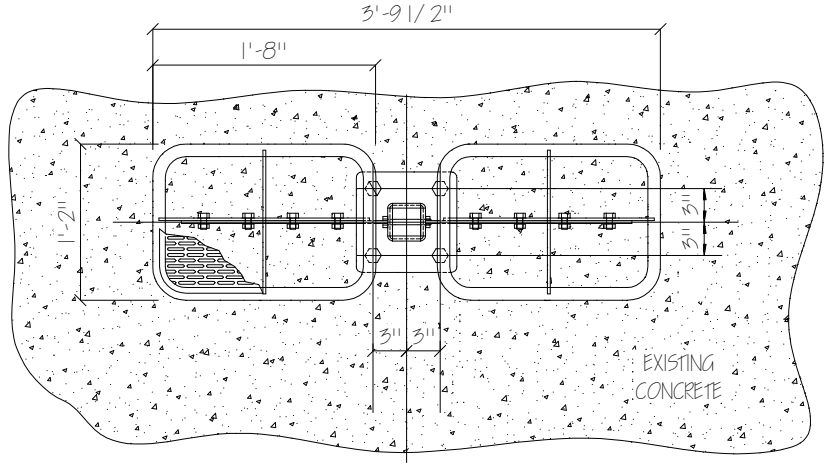

PLAN

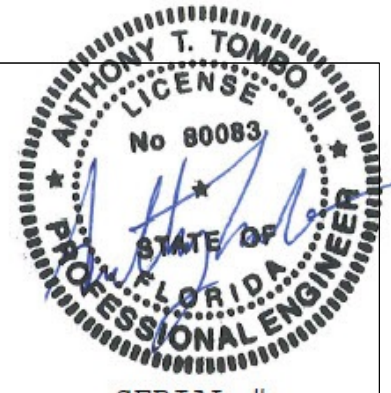
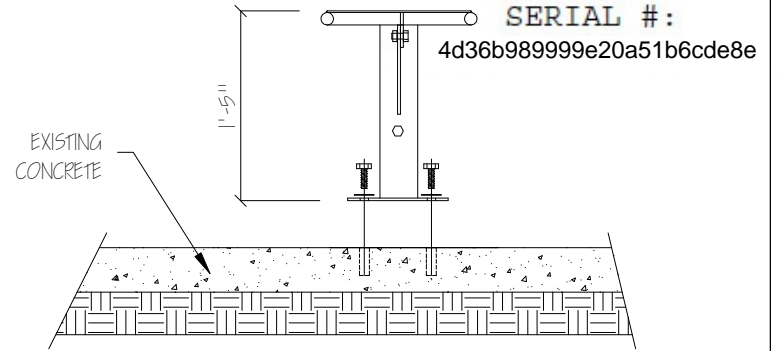

SIDE ELEVATION

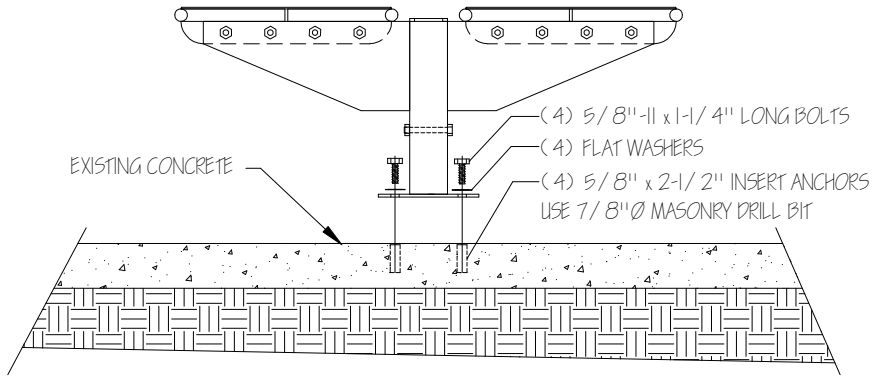

FRONT ELEVATION

NOTE: WHEN INSTALLED ACCORDING TO THESE INSTRUCTIONS, THIS STRUCTURE WILL WITHSTAND THE WIND FORCES CREATED BY A MAXIMUM:

RISK CATEGORY I WIND VELOCITY - UP TO 162MPH (COVERS ALL SOUTH FLORIDA EQUIVALENT TO 175MPH RISK CAT 2)

ANY EXP. CAT. - 12"X18" (1.5 SF) SIGN @ 10.0' CENTERLINE MAX.
UP TO EXP. CAT. C - 18"X24" (3 SF) SIGN @ 8.5' CENTERLINE MAX.

INSTALLATION ON EXISTING CONCRETE

Simme L.L.C. 555 Cherry Drive Eugene, OR 97401 TEL. (541) 358-7995 E-MAIL: SIMME-SEAT@COMCAST.NET		DATE: 3/5/2019	FILE NO: SS-1.DWG
DWN BY: JB	APP BY: CS	PLOT SCALE: NONE	
DWG NO.:		SS-1	